

Fundamentals of flow

There are two methods for studying the movement of flow. One is a method which follows any arbitrary particle with its kaleidoscopic changes in velocity and acceleration. This is called the Lagrangian method. The other is a method by which, rather than following any particular fluid particle, changes in velocity and pressure are studied at fixed positions in space x , y , z and at time t . This method is called the Eulerian method. Nowadays the latter method is more common and effective in most cases.

Here we will explain the fundamental principles needed whenever fluid movements are studied.

4.1 Streamline and stream tube

A curve formed by the velocity vectors of each fluid particle at a certain time is called a streamline. In other words, the curve where the tangent at each point indicates the direction of fluid at that point is a streamline. Floating aluminium powder on the surface of flowing water and then taking a photograph, gives the flow trace of the powder as shown in Fig. 4.1(a). A streamline is obtained by drawing a curve following this flow trace. From the definition of a streamline, since the velocity vector has no normal component, there is no flow which crosses the streamline. Considering two-dimensional flow, since the gradient of the streamline is dy/dx , and putting the velocity in

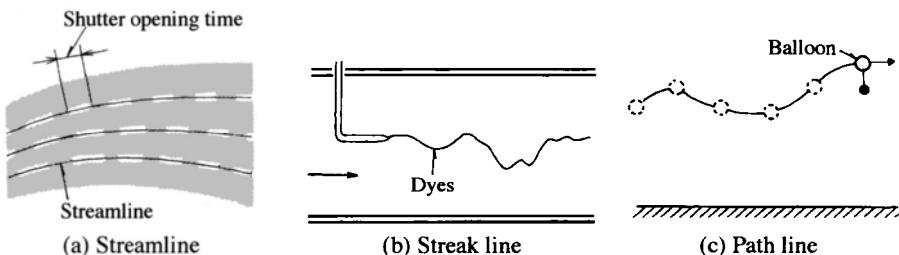

Fig. 4.1 Lines showing flows

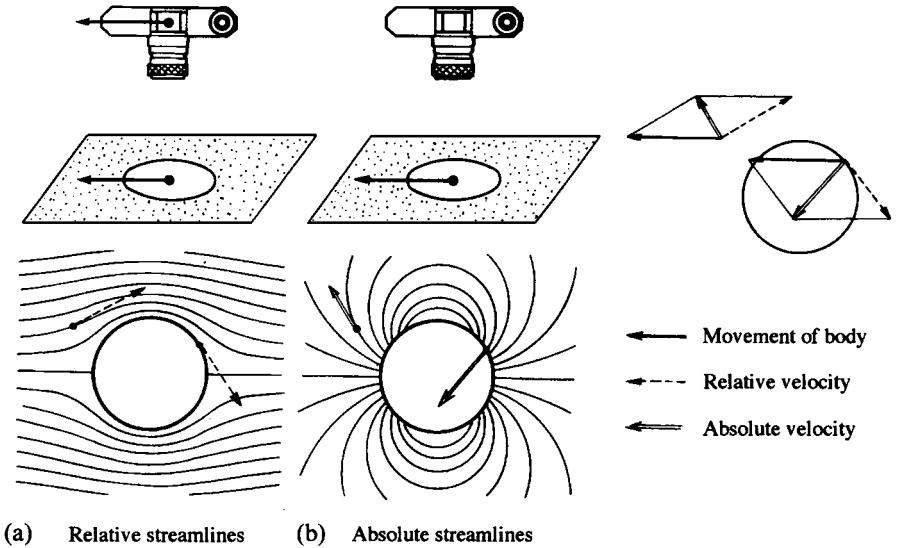

Fig. 4.2 Relative streamlines and absolute streamlines

the x and y directions as u and v respectively, the following equation of the streamline is obtained:

$$dx/u = dy/v \tag{4.1}$$

Whenever streamlines around a body are observed, they vary according to the relative relationship between the observer and the body. By moving both a cylinder and a camera placed in a water tank at the same time, it is possible to observe relative streamlines as shown in Fig. 4.2(a). On the other hand, by moving just the cylinder, absolute streamlines are observed (Fig. 4.2(b)).

In addition, the lines which show streams include the streak line and the path line. By the streak line is meant the line formed by a series of fluid particles which pass a certain point in the stream one after another. As shown in Fig. 4.1(b), by instantaneously catching the lines by injecting dye into the flow through the tip of a thin tube, the streak lines showing the turbulent flow can be observed. On the other hand, by the path line is meant the path of one particular particle starting from one particular point in the stream. As shown in Fig. 4.1(c), by recording on movie or video film a balloon released in the air, the path line can be observed.

In the case of steady flow, the above three kinds of lines all coincide.

By taking a given closed curve in a flow and drawing the streamlines passing all points on the curve, a tube can be formulated (Fig. 4.3). This tube is called a stream tube.

Since no fluid comes in or goes out through the stream tube wall, the fluid is regarded as being similar to a fluid flowing in a solid tube. This assumption is convenient for studying a fluid in steady motion.

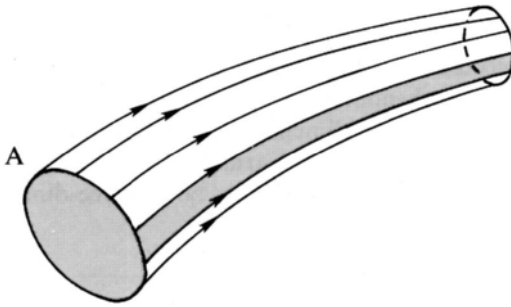

Fig. 4.3 Stream tube

4.2 Steady flow and unsteady flow

A flow whose flow state expressed by velocity, pressure, density, etc., at any position, does not change with time, is called a steady flow. On the other hand, a flow whose flow state does change with time is called an unsteady flow. Whenever water runs out of a tap while the handle is being turned, the flow is an unsteady flow. On the other hand, when water runs out while the handle is stationary, leaving the opening constant, the flow is steady.

4.3 Three-dimensional, two-dimensional and one-dimensional flow

All general flows such as a ball flying in the air and a flow around a moving automobile have velocity components in x , y and z directions. They are called three-dimensional flows. Expressing the velocity components in the x , y and z axial directions as u , v and w , then

$$u = u(x, y, z, t) \quad v = v(x, y, z, t) \quad w = w(x, y, z, t) \quad (4.2)$$

Consider water running between two parallel plates cross-cut vertically to the plates and parallel to the flow. If the flow states are the same on all planes parallel to the cut plane, the flow is called a two-dimensional flow since it can be described by two coordinates x and y . Expressing the velocity components in the x and y directions as u and v respectively, then

$$u = u(x, y, t) \quad v = v(x, y, t) \quad (4.3)$$

and they can be handled more simply than in the case of three-dimensional flow.

As an even simpler case, considering water flowing in a tube in terms of average velocity, then the flow has a velocity component in the x direction only. A flow whose state is determined by one coordinate x only is called a one-dimensional flow, and its velocity u depends on coordinates x and t only:

$$u = u(x, t) \quad (4.4)$$

In this case analysis is even simpler.

Although all natural phenomena are three dimensional, they can be studied as approximately two- or one-dimensional phenomena in many cases. Since the three-dimensional case has more variables than the two-dimensional case, it is not easy to solve the former. In this book three-dimensional formulae are omitted.

4.4 Laminar flow and turbulent flow

On a calm day with no wind, smoke ascending from a chimney looks like a single line as shown in Fig. 4.4(a). However, when the wind is strong, the smoke is disturbed and swirls as shown in Fig. 4.4(b) or diffuses into the peripheral air. One man who systematically studied such states of flow was Osborne Reynolds.

Reynolds used the device shown in Fig. 4.5. Coloured liquid was led to the entrance of a glass tube. As the valve was gradually opened by the handle, the coloured liquid flowed, as shown in Fig. 4.6(a), like a piece of thread without mixing with peripheral water.

When the flow velocity of water in the tube reached a certain value, he observed, as shown in Fig. 4.6(b) that the line of coloured liquid suddenly became turbulent on mingling with the peripheral water. He called the former flow the laminar flow, the latter flow the turbulent flow, and the flow velocity at the time when the laminar flow had turned to turbulent flow the critical velocity.

A familiar example is shown in Fig. 4.7. Here, whenever water is allowed to flow at a low velocity by opening the tap a little, the water flows out smoothly with its surface in the laminar state. But as the tap is gradually opened to let the water velocity increase, the flow becomes turbulent and opaque with a rough surface.

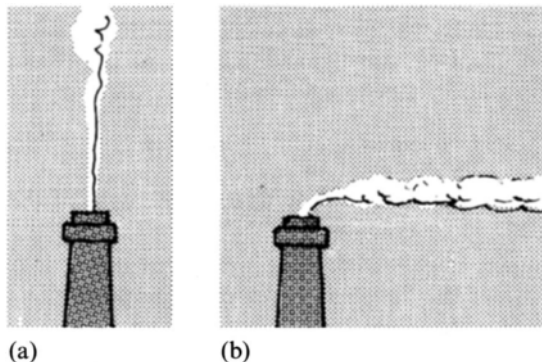

Fig. 4.4 Smoke from a chimney

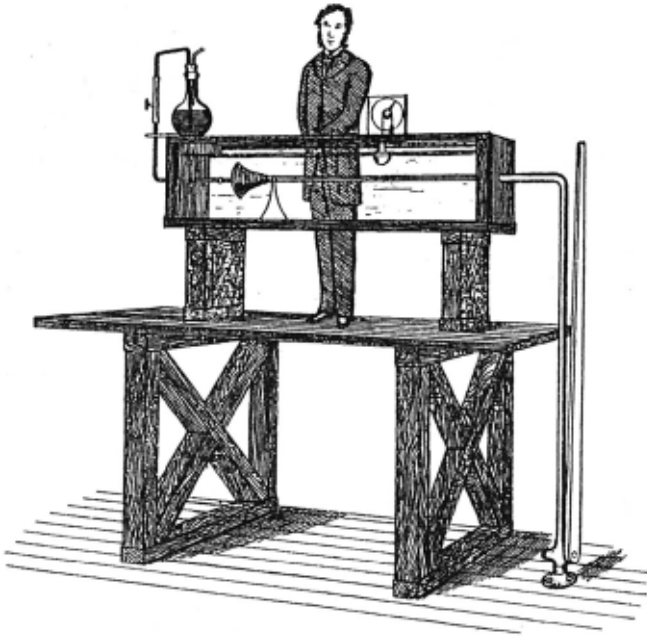

Fig. 4.5 Reynolds' experiment¹

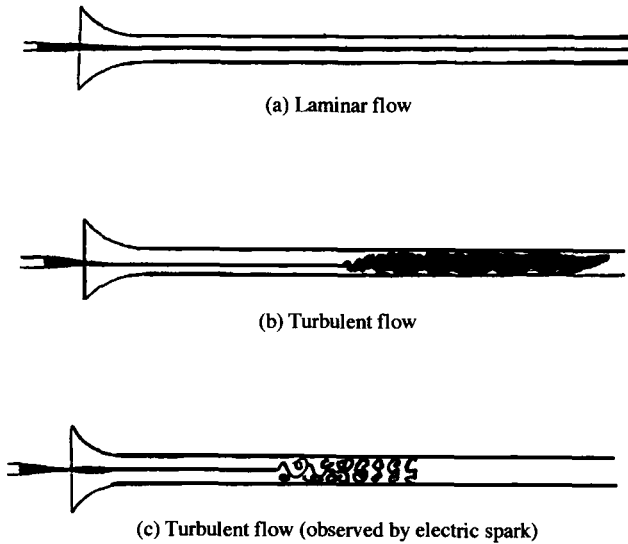

Fig. 4.6 Reynolds' sketch of transition from laminar flow to turbulent flow

¹ Reynolds, O., *Philosophical Transactions of the Royal Society*, 174 (1883), 935.

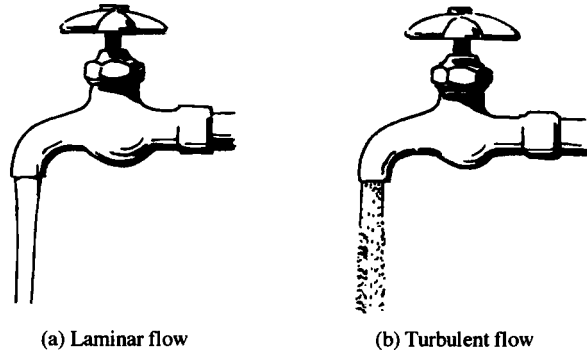

Fig. 4.7 Water flowing from a faucet

4.5 Reynolds number

Reynolds conducted many experiments using glass tubes of 7, 9, 15 and 27 mm diameter and water temperatures from 4 to 44°C. He discovered that a laminar flow turns to a turbulent flow when the value of the non-dimensional quantity $\rho v d / \mu$ reaches a certain amount whatever the values of the average velocity v , glass tube diameter d , water density ρ and water viscosity μ . Later, to commemorate Reynolds' achievement,

$$Re = \frac{\rho v d}{\mu} = \frac{v d}{\nu} \quad (\nu \text{ is the kinematic viscosity}) \quad (4.5)$$

was called the Reynolds number. In particular, whenever the velocity is the critical velocity v_c , $Re_c = v_c d / \nu$ is called the critical Reynolds number. The value of Re_c is much affected by the turbulence existing in the fluid coming into the tube, but the Reynolds number at which the flow remains laminar, however agitated the tank water, is called the lower critical Reynolds number. This value is said to be 2320 by Schiller². Whenever the experiment is made with calm tank water, Re_c turns out to have a large value, whose upper limit is called the higher critical Reynolds number. Ekman obtained a value of 5×10^4 for it.

4.6 Incompressible and compressible fluids

In general, liquid is called an incompressible fluid, and gas a compressible fluid. Nevertheless, even in the case of a liquid it becomes necessary to take compressibility into account whenever the liquid is highly pressurised, such

² Wien, W. und Harms, F., *Handbuch der Experimental Physik*, IV, 4 Teil, Akademische Verlagsgesellschaft (1932), 127.

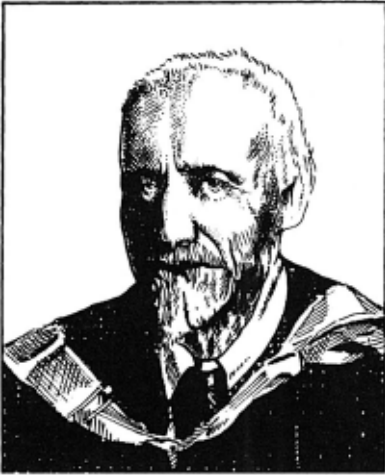

Osborne Reynolds (1842–1912)

Mathematician and physicist of Manchester, England. His research covered all the fields of physics and engineering – mechanics, thermodynamics, electricity, navigation, rolling friction and steam engine performance. He was the first to clarify the phenomenon of cavitation and the accompanying noise. He discovered the difference between laminar and turbulent flows and the dimensionless number, the Reynolds number, which characterises these flows. His lasting contribution was the derivation of the momentum equation of viscous fluid for turbulent flow and the theory of oil-film lubrication.

as oil in a hydraulic machine. Similarly, even in the case of a gas, the compressibility may be disregarded whenever the change in pressure is small. As a criterion for this judgement, $\Delta\rho/\rho$ or the Mach number M (see Sections 10.4.1 and 13.3) is used, whose value, however, varies according to the nature of the situation.

4.7 Rotation and spinning of a liquid

Fluid particles running through a narrow channel flow, while undergoing deformation and rotation, are shown in Fig. 4.8.

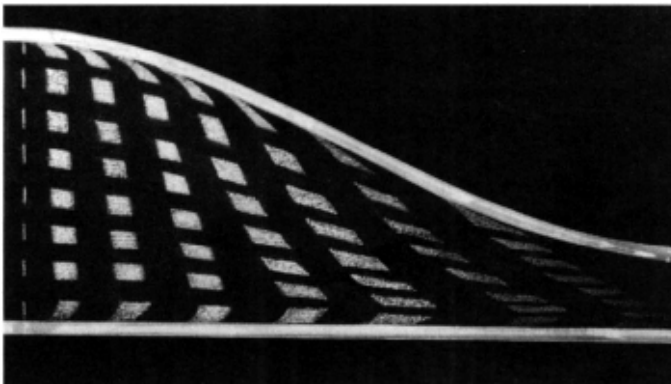

Fig. 4.8 Deformation and rotation of fluid particles running through a narrowing channel

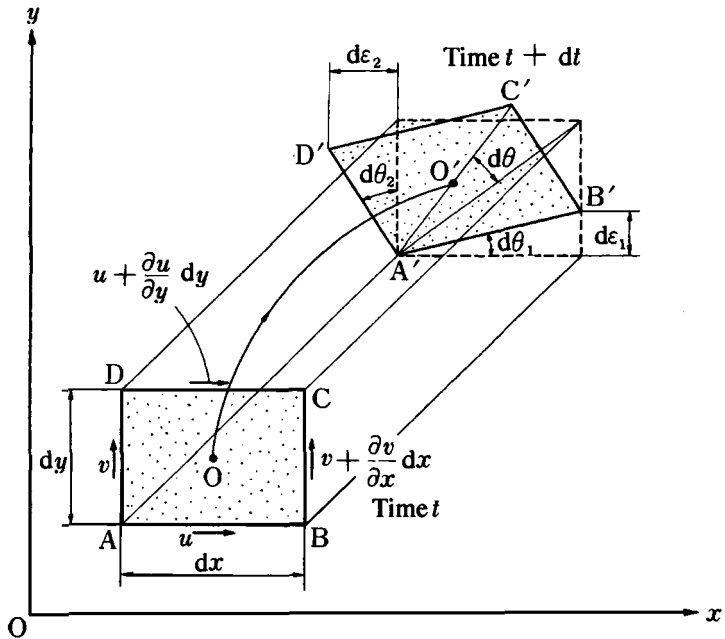

Fig. 4.9 Deformation of elementary rectangle of fluid

Now, assume that, as shown in Fig. 4.9, an elementary rectangle of fluid ABCD with sides dx , dy , which is located at O at time t moves to O' while deforming itself to $A'B'C'D'$ time dt later.

AB in the x direction moves to $A'B'$ while rotating by $d\epsilon_1$, and AD in the y direction rotates by $d\epsilon_2$. Thus

$$d\epsilon_1 = \frac{\partial v}{\partial x} dx dt \quad d\epsilon_2 = -\frac{\partial u}{\partial y} dy dt$$

$$d\theta_1 = \frac{d\epsilon_1}{dx} = \frac{\partial v}{\partial x} dt \quad d\theta_2 = \frac{d\epsilon_2}{dy} = -\frac{\partial u}{\partial y} dt$$

The angular velocities of AB and AD are ω_1 and ω_2 respectively:

$$\omega_1 = \frac{d\theta_1}{dt} = \frac{\partial v}{\partial x} \quad \omega_2 = \frac{d\theta_2}{dt} = -\frac{\partial u}{\partial y}$$

For centre O , the average angular velocity ω is

$$\omega = \frac{1}{2}(\omega_1 + \omega_2) = \frac{1}{2} \left(\frac{\partial v}{\partial x} - \frac{\partial u}{\partial y} \right) \quad (4.6)$$

Putting the term in the large brackets of the above equation as

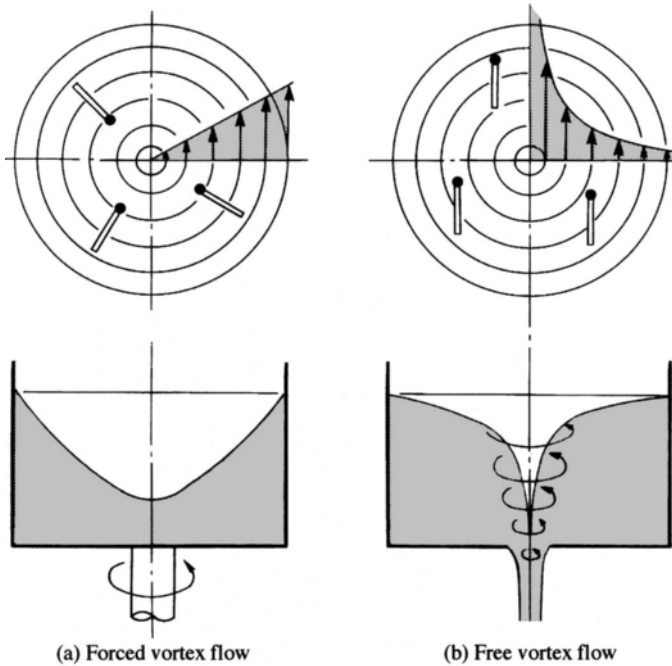

Fig. 4.10 Vortex flow

$$\zeta = \frac{\partial v}{\partial x} - \frac{\partial u}{\partial y} \quad (4.7)^3$$

gives what is called the vorticity for the z axis. The case where the vorticity is zero, namely the case where the fluid movement obeys

$$\frac{\partial v}{\partial x} - \frac{\partial u}{\partial y} = 0 \quad (4.8)$$

is called irrotational flow.

As shown in Fig. 4.10(a), a cylindrical vessel containing liquid spins about the vertical axis at a certain angular velocity. The liquid makes a rotary

³ In general, vector ζ with the following components x, y, z for vector V (components x, y, z are u, v, w) is called the rotation or curl of vector V , which can be written as $\text{rot } V$, $\text{curl } V$ and $\nabla \times V$ (∇ is called nabla). Thus

$$\zeta = \text{rot } V = \text{curl } V = \begin{bmatrix} \frac{\partial w}{\partial y} - \frac{\partial v}{\partial z} & \frac{\partial u}{\partial z} - \frac{\partial w}{\partial x} & \frac{\partial v}{\partial x} - \frac{\partial u}{\partial y} \end{bmatrix}$$

Equation (4.7) is the case of two-dimensional flow where $w = 0$. ∇ is an operator which represents

$$i \frac{\partial}{\partial x} + j \frac{\partial}{\partial y} + k \frac{\partial}{\partial z}$$

where i, j, k are unit vectors on the x, y, z axes.



Fig. 4.11 Tornado

movement along the flow line, and, at the same time, the element itself rotates. This is shown in the upper diagram of Fig. 4.10(a), which shows how wood chips float, a well-studied phenomenon. In this case, it is a rotational flow, and it is called a forced vortex flow. Shown in Fig. 4.10(b) is the case of rotating flow which is observed whenever liquid is made to flow through a small hole in the bottom of a vessel. Although the liquid makes a rotary movement, its microelements always face the same direction without performing rotation. This case is a kind of irrotational flow called free vortex flow.

Hurricanes, eddying water currents and tornadoes (see Fig. 4.11) are familiar examples of natural vortices. Although the structure of these vortices is complex, the basic structure has a forced vortex at its centre and a free vortex on its periphery. Many natural vortices are generally of this type.

4.8 Circulation

As shown in Fig. 4.12, assuming a given closed curve s , the integrated v'_s (which is the velocity component in the tangential direction of the velocity v_s at a given point on this curve) along this same curve is called the circulation

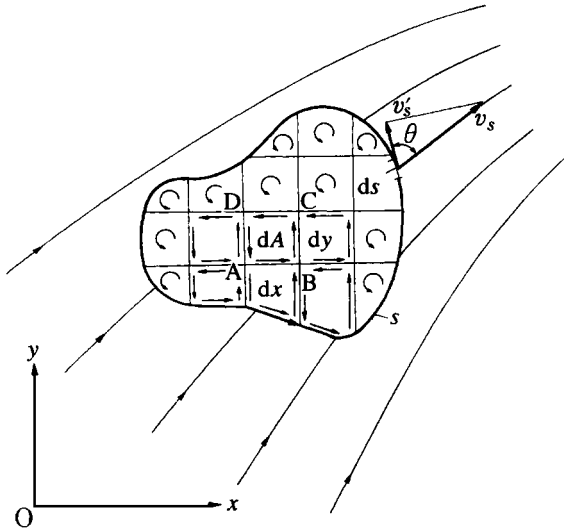

Fig. 4.12 Circulation

Γ . Here, counterclockwise rotation is taken to be positive. With the angle between v_s and v'_s as θ , then

$$\Gamma = \oint v'_s ds = \oint v_s \cos \theta ds \tag{4.9}$$

Next, divide the area surrounded by the closed curve s into microareas by lines parallel to the x and y axes, and study the circulation $d\Gamma$ of one such elementary rectangle ABCD (area dA), to obtain

$$\begin{aligned} d\Gamma &= u dx + \left(v + \frac{\partial v}{\partial x} dx \right) dy - \left(u + \frac{\partial u}{\partial y} dy \right) dx - v dy = \left(\frac{\partial v}{\partial x} - \frac{\partial u}{\partial y} \right) dx dy \\ &= \zeta dx dy = \zeta dA \end{aligned} \tag{4.10}$$

ζ is two times the angular velocity ω of a rotational flow (eqn (4.6)), and the circulation is equal to the product of vorticity by area. Integrate eqn (4.10) for the total area, and the integration on each side cancels leaving only the integration on the closed curve s as the result. In other words,

$$\Gamma = \oint v'_s ds = \oint_A \zeta dA \tag{4.11}$$

From eqn (4.11) it is found that the surface integral of vorticity ζ is equal to the circulation. This relationship was introduced by Stokes, and is called Stokes' theorem. From this finding, whenever there is no vorticity inside a closed curve, then the circulation around it is zero. This theorem is utilised in fluid dynamics to study the flow inside the impeller of pumps and blowers as well as the flow around an aircraft wing.

George Gabriel Stokes (1819–1903)

Mathematician and physicist. He was born in Sligo in Ireland, received his education at Cambridge, became the professor of mathematics and remained in England for the rest of his life as a theoretical physicist. More than 100 of his papers were presented to the Royal Society, and ranged over many fields, including in particular that of hydrodynamics. His 1845 paper includes the derivation of the Navier–Stokes equations.



Reynolds' gleanings

Sir J. J. Thomson wrote:

As I was taking the Engineering course, the Professor I had most to do with in my first three years at Owens was Professor Osborne Reynolds, the Professor of Engineering. He was one of the most original and independent of men and never did anything or expressed himself like anybody else. The result was that we had to trust mainly to Rankine's text books. Occasionally in the higher classes he would forget all about having to lecture and after waiting for ten minutes or so, we sent the janitor to tell him that the class was waiting. He would come rushing into the room pulling on his gown as he came through the door, take a volume of Rankine from the table, open it apparently at random, see some formula or other and say it was wrong. He then went up to the blackboard to prove this. He wrote on the board with his back to us, talking to himself, and every now and then rubbed it all out and said that was wrong. He would then start afresh on a new line, and so on. Generally, towards the end of lecture he would finish one which he did not rub out and say that this proved that Rankine was right after all.

Reynolds never blindly obeyed any scholar's view, even if he was an authority, without confirming it himself.

4.9 Problems

1. Put appropriate words in the blanks below.
 - (a) A flow which does not change as time elapses is called a flow. , and of flow in a steady flow are functions of position only, and most of the flows studied in hydrodynamics are steady flows. A flow which changes as time elapses is called an flow. , and of flow in an unsteady flow are functions of and . Flows such as when a valve is / or the from a tank belong to this flow.
 - (b) The flow velocity is to the radius for a free vortex flow, and is to the radius for a forced vortex flow.
2. When a cylindrical column of radius 5 cm is turned counterclockwise in fluid at 300 rpm, obtain the circulation of the fluid in contact with the column.
3. When water is running in a round tube of diameter 3 cm at a flow velocity of 2 m/s, is this flow laminar or turbulent? Assume that the kinematic viscosity of water is $1 \times 10^{-6} \text{ m}^2/\text{s}$.
4. If the flow velocity is given by the following equations for a two-dimensional flow, obtain the equation of the streamline for this flow:

$$u = kx \quad v = -ky$$
5. If the flow velocities are given as follows, show respectively whether the flows are rotational or irrotational:

| | | |
|---------------|---------------------|---------------------------------|
| (a) $u = -ky$ | (b) $u = x^2 - y^2$ | (c) $u = -\frac{ky}{x^2 + y^2}$ |
| $v = kx$ | $v = -2xy$ | $v = \frac{kx}{x^2 + y^2}$ |

(k is constant).
6. Assuming that the critical Reynolds number of the flow in a circular pipe is 2320, obtain the critical velocity when water or air at 20°C is flowing in a pipe of diameter 1 cm.

7. A cylinder of diameter 1 m is turning counterclockwise at 500 rpm. Assuming that the fluid around the cylinder turns in contact with the column, obtain the circulation around it.